



P/N 199R-10272

# Ford Mustang 4.6L 2V NOSzle Kit



Kit Number 08100NOS

# OWNER'S MANUAL

**CONGRATULATIONS** on purchasing your NOS Nitrous Oxide Injection System! Your system is composed of the highest quality components available. It should provide many miles of trouble-free performance when used correctly. If you have any questions regarding the performance of your system, **call NOS Technical Service at 1-714-546-0592, fax to 1-714-545-8319, or email to nos@support.holley.com.**

**NOTICE: The installation of Nitrous Oxide Systems, Inc. products signifies that you have read this document and have agreed to the terms stated within.**

It is the purchaser's responsibility to follow all installation instruction guidelines and safety procedures supplied with the product as it is received by the purchaser to determine the compatibility of the product with the vehicle or the device the purchaser intends to install the product on.

Nitrous Oxide Systems Inc. assumes no responsibility for damages occurring from accident, misuse, abuse, improper installation, improper operation, lack of reasonable care, or all previously stated reasons resulting from incompatibility with other manufacturers' products.

Nitrous Oxide Systems Inc. assumes no responsibility or liability for damages incurred by the use of products manufactured or sold by Nitrous Oxide Systems Inc. on vehicles used for competition or racing.

Nitrous Oxide Systems Inc. neither recommends nor condones the use of products manufactured or sold by Nitrous Oxide Systems Inc. on vehicles, which may be driven on public roads or highways, and assumes no responsibility for damages incurred by such use.

NOS nitrous oxide is legal for use in most states when used in accordance with state and local traffic laws. NOS does not recommend or condone the use of its products in illegal racing activities.

NOS has not pursued California Air Research Board (CARB) exemptions for its kits, hence, they are not legal for use on pollution-controlled vehicles in California. A correctly installed NOS nitrous system should not alter the emission control performance of your vehicle under standard EPA test cycle conditions.

## **HAZARDS DEFINED**

This manual presents step-by-step instructions that describe the process of installing your NOS Nitrous Oxide Injection System. These procedures provide a framework for the installation and operation of this kit. Parts are referenced by name and number to avoid confusion. Within the instructions, you are advised of potential hazards, pitfalls, and problems to avoid. The following examples explain the various hazard levels:

**WARNING! Failure to comply with instructions may result in injury or death.**

**CAUTION! Failure to comply with instructions may result in damage to equipment.**

**NOTE:** This information is important, needs to be emphasized, and is set apart from the rest of the text.

**HINT:** These special instructions provide a handy work tip.

## **NITROUS OXIDE INJECTION SYSTEM SAFETY TIPS**

### **WARNINGS**

**IT IS NOT LEGAL TO ENGAGE NITROUS OXIDE INJECTION SYSTEMS ON PUBLIC ROADS OR HIGHWAYS. NITROUS OXIDE INJECTION SYSTEMS ARE ONLY TO BE ENGAGED DURING SANCTIONED COMPETITION OR RACING EVENTS.**

The NOSzle Kit is not intended for use on hatchback type vehicles without the use of NOS part numbers 16160 (External Aluminum Blow-Down Tube) and 16166 (Racer Safety Pressure Relief Cap).

Some mustang ECUs are programmed with a 120mph fuel cutoff. If the vehicle reaches this speed with the nitrous oxide injection system engaged, severe engine damage may result.

This kit includes flexible nitrous and fuel lines for connection between the NOSzles and the distribution block(s). When installed according to the instructions in this the manual, the lines are legal for use in NHRA competition, starting in 2002.

Do not attempt to start the engine if the nitrous has been injected while the engine was not running. Disconnect the coil wire and turn the engine over with the throttle wide open for several revolutions before attempting to start. Failure to do so can result in extreme engine damage.

Never permit oil, grease, or any other readily combustible substances to come in contact with cylinders, valves, solenoids, hoses, and fittings. Oil and certain gases (such as oxygen and nitrous oxide) may combine to produce a highly flammable condition.

Never interchange nitrous and fuel solenoids. Failure to follow these simple instructions can result in extreme engine damage and/or personal injury.

Never drop or violently strike the bottle. Doing so may result in an explosive bottle failure.

Never change pressure settings of safety relief valve on the nitrous bottle valve. Increasing the safety relief valve pressure settings may create an explosive bottle hazard.

Identify the gas content by the NOS label on the bottle before using. If the bottle is not identified to show the gas contained, return the bottle to the supplier.

Do not deface or remove any markings, which are used for content identification.

Nitrous bottle valves should always be closed when the system is not being used.

Notify the supplier of any condition, which might have permitted any foreign matter to enter the valve or bottle.

Keep the valves closed on all empty bottles to prevent accidental contamination.

After storage, open the nitrous bottle valve for an instant to clear the opening of any possible dust or dirt.

It is important that all threads on the valves and solenoids are properly mated. Never force connections that do not fit properly.

## TABLE OF CONTENTS

What is Nitrous Oxide?.....	4
Do's and Don'ts of Nitrous Oxide.....	4
Chapter 1 Introduction to Your NOS Nitrous Oxide Kit.....	4
1.1 General Information.....	4
1.2 System Requirements.....	5
1.3 Kit Components.....	5
Chapter 2 Kit Installation.....	7
2.1 Bottle Mounting Instructions.....	7
2.2 Bottle Orientation.....	7
2.3 Bottle Installation.....	7
2.4 NOSzle Installation.....	8
2.5 High-Pressure Flexible Fuel & Nitrous Oxide Lines.....	12
2.5.1 High-Pressure Line Installation.....	13
2.6 Main Nitrous Feed Line Mounting.....	13
2.7 Main Fuel Pressure Safety Switch.....	13
2.8 Main Fuel Feed Line Installation.....	13
2.9 Electrical System.....	14
2.9.1 Wide-Open Throttle Switch Installation.....	14
2.9.2 RPM Window Switch Installation.....	15
2.9.3 Arming Switch Installation.....	16
2.9.4 Harness Routing.....	17
2.9.5 Solenoid Connection.....	17
2.9.6 Arming Switch-Switched 12V Connection.....	17
2.9.7 Fuel Pressure Safety Switch.....	18
2.10 Testing for Proper Operation without Nitrous Bottle Hooked Up.....	18
2.11 Preparing for Operation.....	18
Chapter 3 Tuning.....	19
Appendix A Troubleshooting Guide.....	19

## WHAT IS NITROUS OXIDE?

### NITROUS OXIDE...

...Is a cryogenic gas composed of nitrogen and oxygen molecules

...Is 36% oxygen by weight

...Is non-flammable by itself

...Is stored as a compressed liquid

...Exists in two grades—U.S.P. and Nitrous Plus:

- ❑ U.S.P. is medical grade nitrous oxide; its common use is dental and veterinary anesthesia. It is also commonly used as a propellant in canned whipped cream. U.S.P. is not available to the public.
- ❑ Nitrous Plus differs from U.S.P. in that it contains trace amounts of sulphur dioxide added to prevent substance abuse. Nitrous Plus is intended for automotive applications and is available for sale to the public.

In automotive applications, Nitrous Plus and fuel are injected into the engine's intake manifold, which produces the following results:

- ❑ Lowers engine intake air temperature, producing a dense inlet charge.
- ❑ Increases the oxygen content of the inlet charge (air is only 22 percent oxygen by weight).
- ❑ Increases the rate at which combustion occurs in the engine's cylinders.

## DO'S AND DON'TS OF NITROUS OXIDE

### Do's

- ❑ Read all instructions before attempting to install your NOS nitrous system.
- ❑ Make sure your fuel delivery system is adequate for the nitrous jetting you have chosen. Inadequate fuel pressure or flow will result in engine damage.
- ❑ Use 14 gauge (minimum) wire when installing electrical system components.
- ❑ Use high-quality connections at all electrical joints.
- ❑ Use Teflon-based paste on pipe-style fittings.
- ❑ Make sure your engine and related components (ignition, carburetor, and driveline) are in proper working condition.
- ❑ **If nitrous is accidentally injected into the engine when it is not running, remove the engine coil wire, open the throttle, and crank the engine 10 to 15 seconds before starting. Failure to do so can result in an explosive engine failure.**
- ❑ **Use your NOS nitrous system only at wide-open throttle and at engine speeds above 3000 RPM.**
- ❑ **Install a proper engine to chassis ground. Failure to do so may result in an explosive failure of the main nitrous supply line.**
- ❑ Use a high-quality fuel, as suggested in Chapter 3, Baseline Tuning Suggestions.

### Don'ts

- ❑ Engage your nitrous system with the engine off. Severe engine damage can occur.
- ❑ Modify NOS nitrous systems (if you need a non-stock item, call NOS Technical Service for assistance)
- ❑ Overtighten AN type fittings.
- ❑ Use Teflon Tape on any pipe threads. Pieces of Teflon tape can break loose and become lodged in the nitrous or fuel solenoids or solenoid filters. Debris lodged in a nitrous or fuel solenoid can cause catastrophic engine failure.



- ❑ Use sealant of any kind on AN type fittings.
- ❑ Allow nitrous pressure to exceed 1100 psi. Excessive pressure can cause swelling or in extreme cases failure of the nitrous solenoid plunger. Solenoid plungers are designed so that pressure-induced failures will prevent the valve from operating. No leakage should occur with this type of failure.
- ❑ **Inhale nitrous oxide. Death due to suffocation can occur.**
- ❑ **Allow nitrous oxide to come in contact with skin. Severe frostbite can occur.**
- ❑ **Use octane boosters that contain methanol. Fuel solenoid failure may occur, producing severe engine damage.**

## Chapter 1 Introduction to Your NOS Nitrous Oxide Kit

### 1.1 General Information

Kit Number 08100NOS is intended for use on 1996-1999 return style fuel systems and 1999 1/2 through 2002 return-less fuel system Ford Mustangs with 2V 4.6L V-8 engines. Power output is increased by 100 or 125 HP over stock depending on the selected jet size combination.

Kit Number 08100NOS flows additional fuel during nitrous activation through one of the axial passages in all eight NOSzles. Fuel metered by the engine control unit through the conventional fuel injector, and nitrous flow is introduced into the engine at the same original equipment location. Such a location ensures proper nitrous and fuel distribution, optimum fuel atomization, and better combustion of the induced combustible mixture. Driveability, fuel economy, and exhaust emission should not be affected under normal (part throttle) vehicle operation.

## 1.2 System Requirements

When used correctly, Kit Number 08100NOS is designed to work with stock 2V Ford internal engine and driveline components when jetted for up to 125 HP. Colder plugs (non-platinum, gapped at .035) are strongly recommended. Please check Table 2 on Page 20 for recommended spark plug heat range selection. If the jetting is increased over 125 HP, it is advised to upgrade the fuel delivery system to ensure safe operation. Higher HP levels also require additional modifications, such as forged pistons.

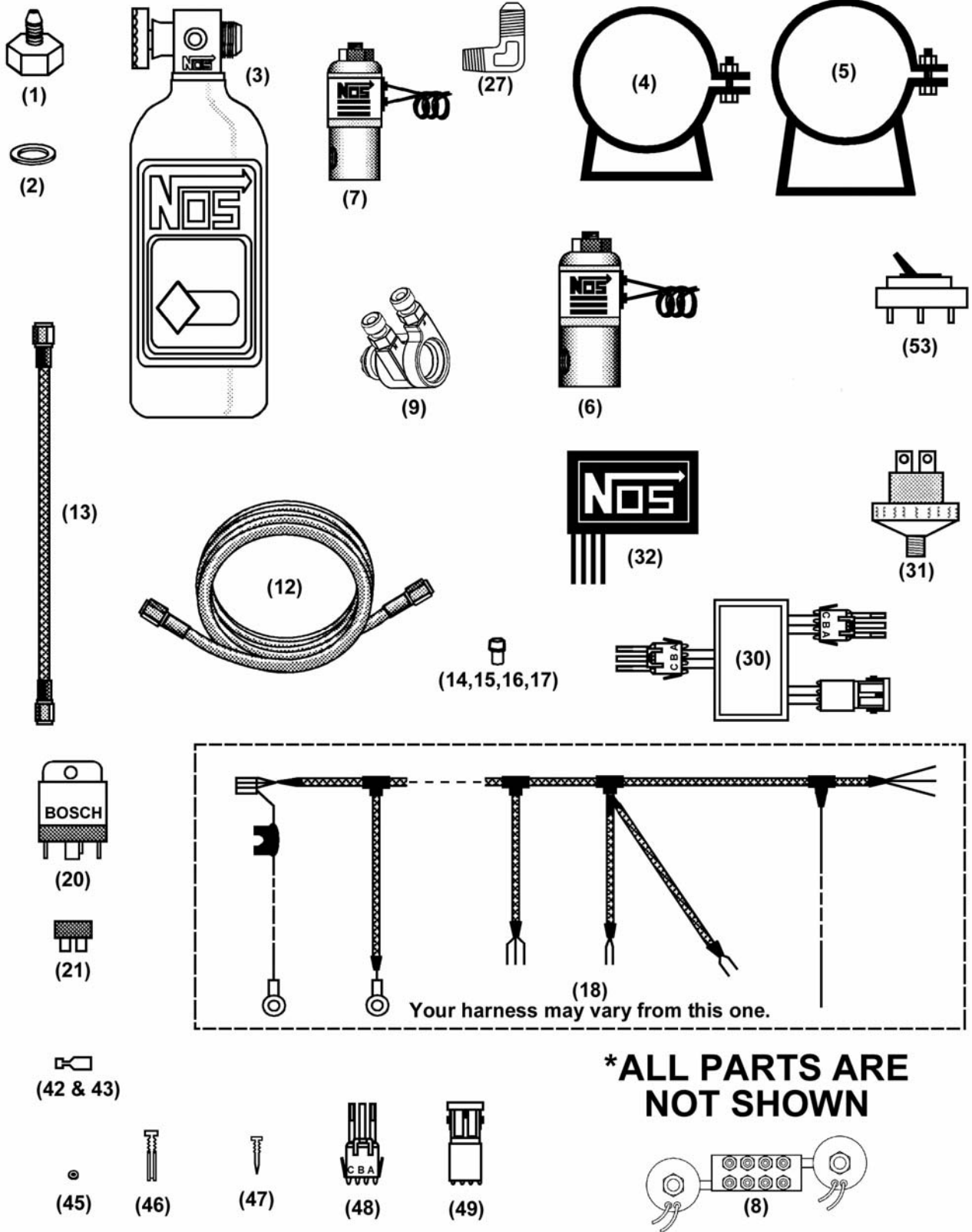
## 1.3 Kit Components

Before beginning the installation of your NOS kit, compare the components in your kit with those listed in Table 2. If any components are missing, please contact NOS Technical Support at 714-546-0592.

**Table 1 Kit Number 08100NOS Parts List**

Item	Description	Quantity	NOS P/N
(1)	Bottle Nut Adapter	1	16220-SNOS
(2)	Bottle Valve Washer	1	16210-SNOS
(3)	#10 Nitrous Bottle	1	14745-SNOS
(4)	Bottle Mounting Bracket, Short	1	14126-SNOS
(5)	Bottle Mounting Bracket, Long	1	14127-SNOS
(6)	N <sub>2</sub> O Super Pro Shot Solenoid	1	16045NOS
(7)	Cheater Fuel Solenoid	1	16050NOS
(8)	4.6L NOSzle Solenoid Assembly	1	283R515A
(9)	NOSzle Assembly	8	21R901A
(10)	High-Pressure Nitrous Line Assemblies*	8	52R421-1A
(11)	High-Pressure Fuel Line Assemblies*	8	52R421-2A
(12)	16 ft. 4AN Nitrous Supply Hose (Blue)	1	15300-SNOS
(13)	4AN-12" Fuel Hose (Red)	1	15211NOS
(14)	0.009" Funnel Jet	8	13745-09-SNOS
(15)	0.010" Funnel Jet	8	13745-10-SNOS
(16)	0.016" Funnel Jet	8	13745-16-SNOS
(17)	0.018" Funnel Jet	8	13745-18-SNOS
(18)	4.6L Main Wiring Harness	1	271R925A
(19)	Toggle Switch	1	15600-SNOS
(20)	30 Amp Relay	1	15618-SNOS
(21)	25 Amp Fuse	1	15893-25-SNOS
(22)	Sheet metal screws*	10	-----
(23)	1/8 NPT Brass T Fitting*	1	16776NOS
(24)	1/8 NPT Brass Short Nipples*	3	19R896
(25)	4AN x 1/8 NPT Adapter (Red)*	1	17961NOS
(26)	1/16 NPT x 1/8 NPT Female Fitting*	1	16785NOS
(27)	90° Adapter-4AN x 1/8 NPT (Red)*	1	17661NOS
(28)	N <sub>2</sub> O Filter*	1	15562NOS
(29)	Solenoid Bracket*	1	49R2066
(30)	4.6L Mustang WOT Switch	1	15629-SNOS
(31)	4.6L Mustang Fuel Pressure Switch	1	89R686
(32)	RPM Window Switch Assembly	1	200R527A
(33)	Screw M6 x 1.0 x 32*	9	5R2163
(34)	Intake Adapter Spacer*	1	40R727
(35)	Intake Adapter Spacer*	1	8R2259
(36)	Intake Adapter Spacer*	1	40R728
(37)	Fuel Rail Spacer*	4	40R729
(38)	2600 RPM Module Chip*	1	15800-26-SNOS
(39)	6000 RPM Module Chip*	1	15800-60-SNOS
(40)	5200 RPM Module Chip*	1	15800-52-SNOS
(41)	12000 RPM Module Chip*	1	15800-120-SNOS
(42)	Male Spade Connector	2	15886B-SNOS
(43)	Female Spade Connector	5	15885B-SNOS
(44)	Scotchlock*	2	15891-SNOS
(45)	Packard Connector Seal	6	27R785
(46)	Packard Pin (Female)	3	204R239
(47)	Packard Pin (Male)	3	204R355
(48)	3-Pin Packard Connector (Male)	1	204R358
(49)	3-Pin Packard Connector (Female)	1	204R359
(50)	22 Ga. Yellow Wire*	1	1822-Y-SNOS
(51)	22 Ga. Red Wire*	1	1822-R-SNOS
(52)	¼" Ring Terminal*	3	15882-SNOS

Figure 1 Kit Number 08100NOS Component Identification



## Chapter 2 Kit Installation

### 2.1 Bottle Mounting Instructions

Accurate calibration of your NOS nitrous system depends on the bottle remaining at a stable temperature. Mount the bottle away from heat sources, such as the engine compartment or exhaust system, and away from windows, where the bottle is exposed to direct sunlight.

### 2.2 Bottle Orientation

Bottle placement is critical to the performance of your NOS nitrous system. It is important to understand how the bottle valve and siphon tube are assembled to properly orient the bottle in your vehicle and ensure that it picks up liquid nitrous while undergoing acceleration. All nitrous bottles are assembled so that the bottom of the siphon tube is at the bottom of the bottle and opposite the bottle label (Figure 2).

Whenever the bottle is mounted in a lay-down position, the valve handle must be towards the front of the vehicle with the label facing up (Figure 3A).

If the bottle is mounted vertically, the valve handle and label must face toward the front of the vehicle (Figure 3B). This orientation will position the siphon tube at the back of the bottle where the liquid  $N_2O$  will be during acceleration.

**WARNING! DO NOT attempt to remove the siphon tube without completely emptying the bottle of all  $N_2O$  and pressure.**

A bottle mounted upside-down must have the siphon tube removed before use (Figure 3C). Non-siphon bottles can be specially ordered from NOS.

If the bottle must be mounted parallel to the axles of the vehicle (sideways), the valve handle and label must be angled at approximately  $45^\circ$  toward the front of the vehicle (Figure 3D). This orientation will position the siphon tube toward the rear of the bottle.

**NOTE:** When using a bottle with a siphon tube, the tall bracket should be at the valve end of the bottle and the short bracket at the bottom (Figure 3E).

The most efficient mounting is the lay-down position (Figure 3A) with the valve handle toward the front of the vehicle. This position allows the greatest amount of liquid to be used before the siphon tube begins to pick up gaseous nitrous oxide.

Find a position in the rear of your Ford Mustang vehicle that meets your personal preference. Make sure that it meets the guidelines show in Figure 3.

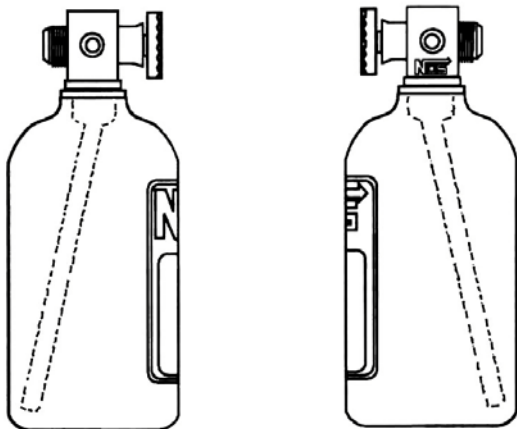


Figure 2 Nitrous Bottle Siphon Tube Orientation

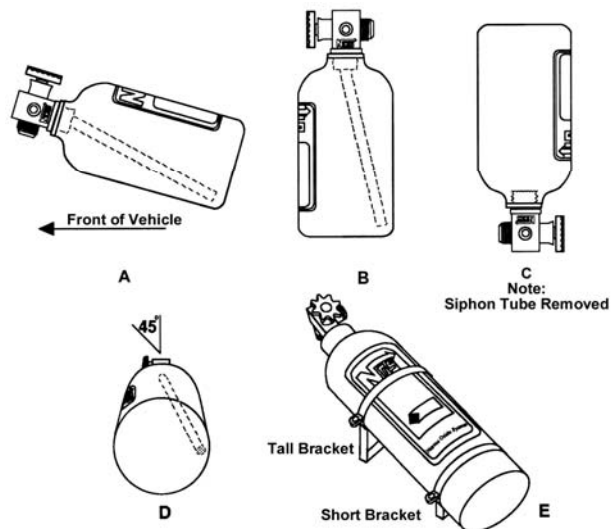


Figure 3 Nitrous Bottle Mounting Orientations

### 2.3 Bottle Installation

After you have determined the location and orientation of the nitrous bottle, use the following procedure to install the bottle:

**NOTE:** Numbers in parentheses ( ) refer to the parts list (Table 1).

1. Install the bottle nut adapter (1) and washer (2) on the nitrous bottle (3), and tighten securely.
2. Slip the bottle mounting brackets (4 & 5) onto the nitrous bottle, as shown in Figure 3E.



**CAUTION!** When drilling or punching holes for these fasteners be aware what component, wires or hoses are located or routed behind the general area to avoid vehicle or equipment malfunction.

3. Use the assembled bottle/bracket unit as a pattern to mark for hole drilling. Drill four 11/32" holes in the mounting surface for the bottle bracket bolts. **Make sure the holes are in a position that does not damage other components.**
4. Mount the brackets securely to the surface (recommended minimum of 5/16" bolts or No. 12 sheet metal screws).
5. Secure the nitrous bottle in the mounting brackets and tighten the bracket clamps.

## 2.4 NOSzle Installation

**WARNING!** Do not smoke or carry lighted tobacco or open flame of any type when working on or near any fuel-related components. Highly flammable mixtures are always present and may be ignited. Failure to follow these instructions may result in personal injury.

1. Figure 4 shows the recommended placement of the NOSzle kit on the engine.

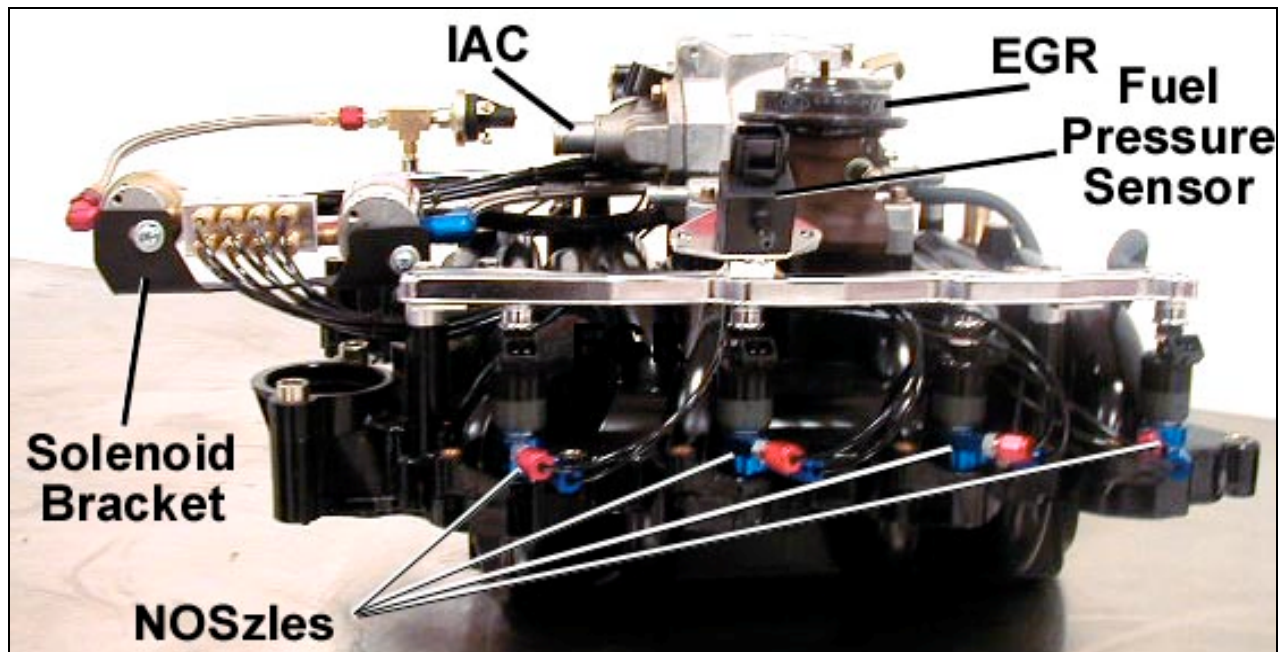


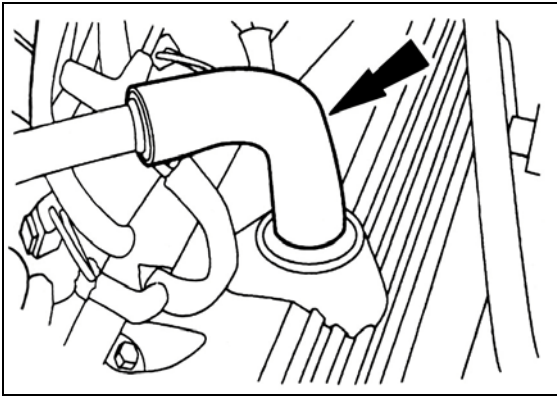
Figure 4

2. Disconnect the battery.

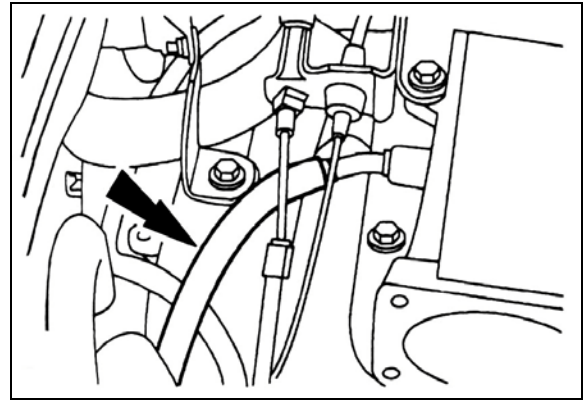
**WARNING!** Fuel in the fuel system remains under high pressure even after the engine is shut off. Before working on or disconnecting any of the fuel lines or fuel system components, the fuel pressure must be relieved. Failure to follow these instructions may result in personal injury

3. Relieve fuel pressure via the Schrader valve and disconnect the fuel line. Collect or clean any fuel spilled in the engine bay area. Check the factory repair manual for the correct procedure.
4. To ensure proper re-installation of hoses, tubes, and cables, either draw a sketch or mark the locations of the tubes and hoses by using a piece of masking tape.
5. Remove the air inlet tube by loosening the clamps, disconnect the PCV hoses and the electric connector to the inlet air temperature sensor.
6. Disconnect the accelerator cable, speed control actuator and return spring.
7. Remove the bolts and position the cables and bracket out of the way.
8. Remove the breather tube (Figure 5).
9. Disconnect the evaporative emission return line (Figure 6).





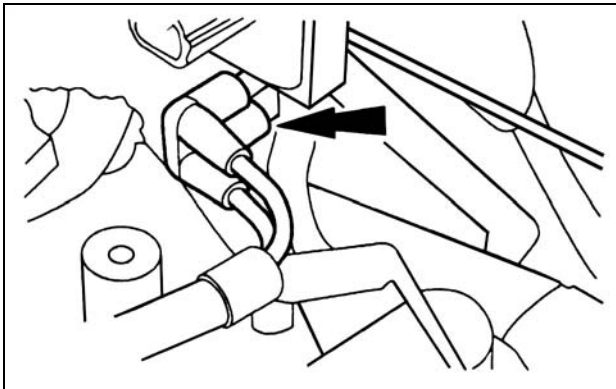
**Figure 5**



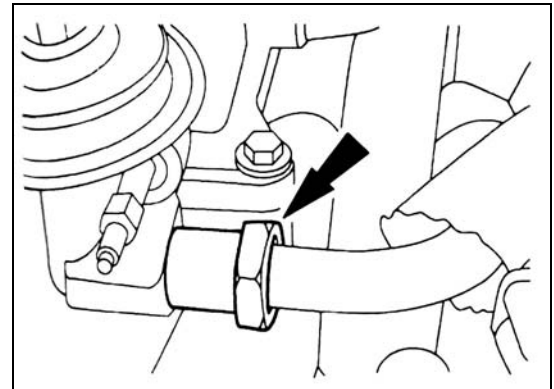
**Figure 6**

10. Disconnect the EGR vacuum regulator solenoid vacuum supply (Figure 7).

11. Loosen the stainless steel tube nut from the EGR valve (Figure 8).

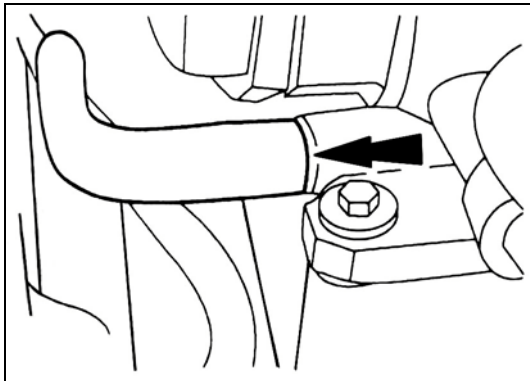


**Figure 7**

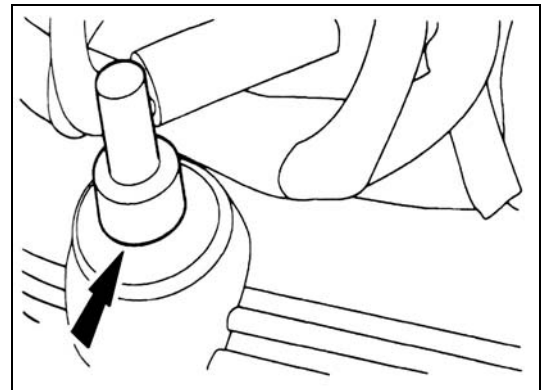


**Figure 8**

12. Disconnect the positive crankcase ventilation (PCV) hose from the base of the throttle body (Figure 9).



**Figure 9**



**Figure 10**

13. Remove PCV valve and hose as an assembly (Figure 10).

14. Disconnect the vacuum line from the EGR valve.

15. Disconnect the idle air valve electrical connector (Figure 11).

16. Disconnect the main vacuum supply from the base of the throttle body adapter.

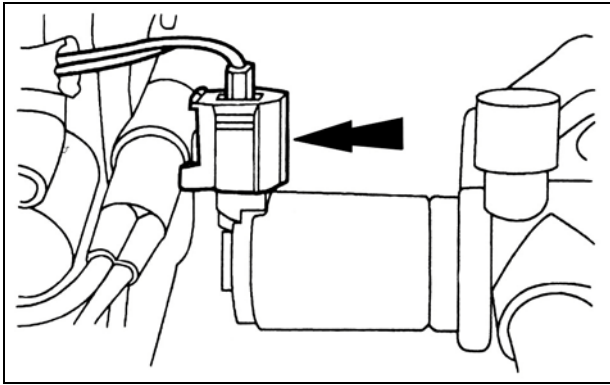


Figure 11

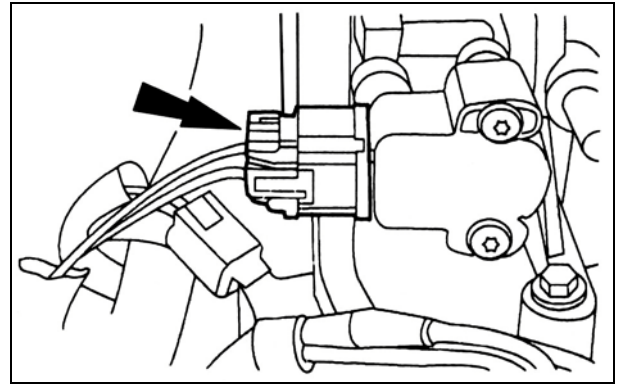


Figure 12

17. Disconnect the throttle position sensor electrical connector (Figure 12).
18. Remove the intake manifold adapter with an 8mm socket.
19. Remove the throttle body and adapter as an assembly.
20. Disconnect the fuel pressure sensor electrical connector (Figure 13).

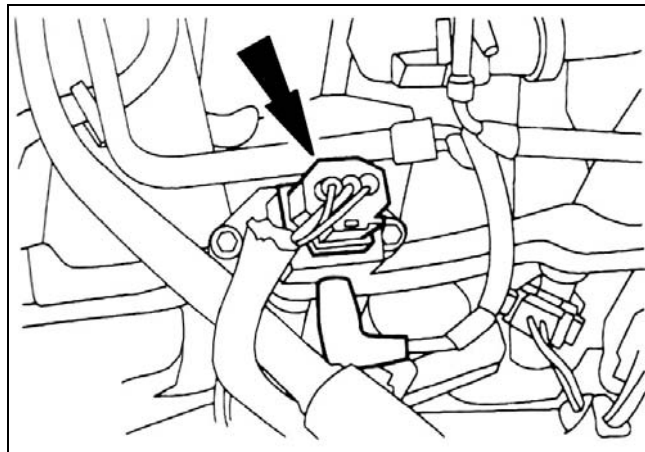


Figure 13

21. Disconnect the fuel charging ground wire (Figure 14).

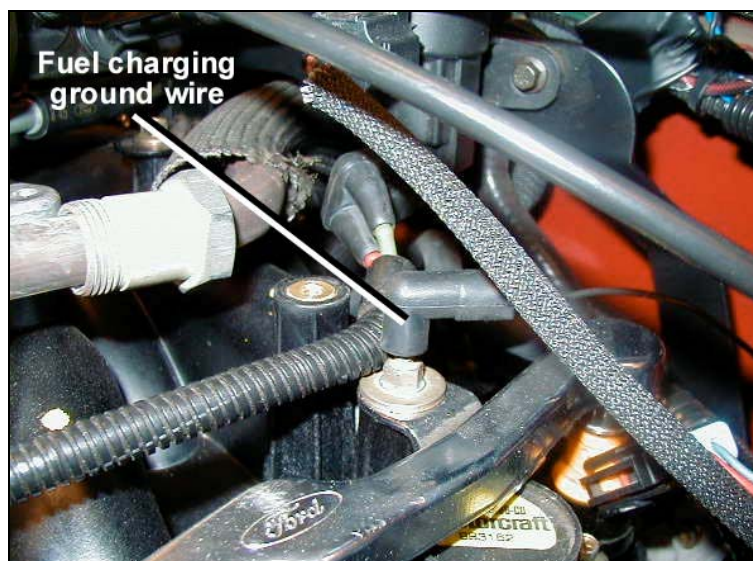


Figure 14

22. Disconnect the eight fuel injector electrical connectors.
23. Loosen and remove the four fuel rail hold-down studs (Figure 15).

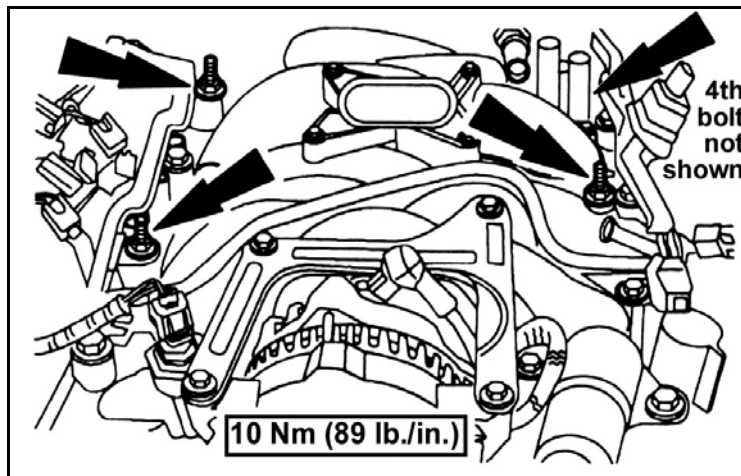


Figure 15

24. Remove the injectors and fuel rail as an assembly.
25. Remove the two driver side screws of the upper alternator support bracket (Figure 16).

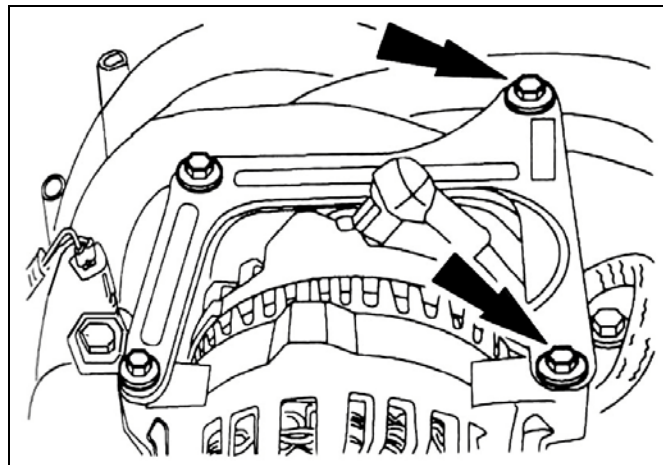


Figure 16

26. Install the solenoid/distribution block assembly to the upper generator support bracket. Torque the two bolts to 89 lb./in. (10 Nm).
  27. Lubricate the O-rings of the NOSzles and install the NOSzle into the fuel injector bosses orienting the nitrous and fuel fittings towards the valve covers. Use SAE 10W-30 engine oil or equivalent to lubricate the O-rings.
  28. Lubricate the O-rings of the fuel injectors and install the injector and rail assembly onto the NOSzles. Use SAE 10W-30 engine oil or equivalent to lubricate the O rings.
  29. The kit supplied with 5 cylindrical spacers has 4 of equal length and one that is shorter. Use the shorter adapter in Step 32. Locate the four fuel rail spacers between the fuel rail mounting ears and the intake manifold bosses.
  30. Install the four supplied 6 x 32mm fuel rail bolts and torque to 89 lb./in. (10Nm).
  31. Connect the eight fuel injector wires.
  32. Install intake manifold adapter by placing the spacer and gasket between the adapter and the manifold. Gasket should be positioned between the spacer and the intake adapter. Locate the cylindrical spacer (shorter one) between the intake boss and the adapter. Install the five 6 x 32mm screws and hand tighten.
- HINT:** *It will be easier to connect the EGR tube to the EGR valve before placing the intake adapter in its proper location.*
33. Connect the fuel charging ground wire to the valve cover stud.
  34. Connect the fuel pressure sensor electrical connector.
  35. Connect the throttle position electrical connector.



36. Connect the idle air control electrical connector.
37. Connect the main vacuum supply to the base of the throttle body adapter.
38. Connect the vacuum line to the EGR valve.
39. Install the PCV valve and hose assembly.
40. Connect the PCV hose to the base of the throttle body.
41. Tighten the EGR tube nut to 26 lb./ft. (35 Nm) of torque.
42. Tighten the intake adapter bolts in a criss-cross pattern and torque to 89lb./in.(10Nm).
43. Connect the EGR vacuum regulator solenoid electrical connector.
44. Connect the evaporative emission return line.
45. Install the breather tube.
46. Position the accelerator and speed control cables and install the bracket to 89 lb./in. (10Nm) of torque.
47. Connect the accelerator cable, speed control actuator and return spring.
48. Connect the fuel line, pull on fitting to make sure it is fully engaged, and install safety clip.
49. Install air inlet duct and tighten the clamps.
50. Connect the inlet air temperature sensor electrical connector.

## 2.5 High-Pressure Flexible Fuel & Nitrous Oxide Lines

This kit contains sixteen fully terminated, high-pressure, flexible lines. Eight lines supply the fuel from the metering block to the eight NOSzles and eight lines supply the nitrous to the eight NOSzles.

**WARNING! Special attention has been given when connecting the lines to the metering block and the NOSzles. Serious engine damage will occur if high-pressure lines are not connected to the correct fittings and/or ports.**

The metering block comes completely assembled and is important to identify the fuel and nitrous fittings. The fuel solenoid (7) P/N 16050NOS (smaller in size) is at the front of the engine and is connected to the upper passage of the distribution block. The upper fittings of the distribution block are therefore to be used for the fuel lines (lines with the red anodized fitting). The nitrous solenoid (6) P/N 16045NOS (larger in size) is at the back of the engine and is connected to the lower passage of the distribution block. The lower fittings of the distribution block are therefore to be used for the nitrous lines (lines with the blue anodized fitting). See Figure 17. The NOSzle is marked with an "N" for nitrous oxide and an "F" for fuel. The red anodized fitting is to be installed with the selected funnel jet to the "F" port of the NOSzle. The blue anodized fitting is to be installed with the selected funnel jet to the "N" port of the NOSzle. See Figure 18.

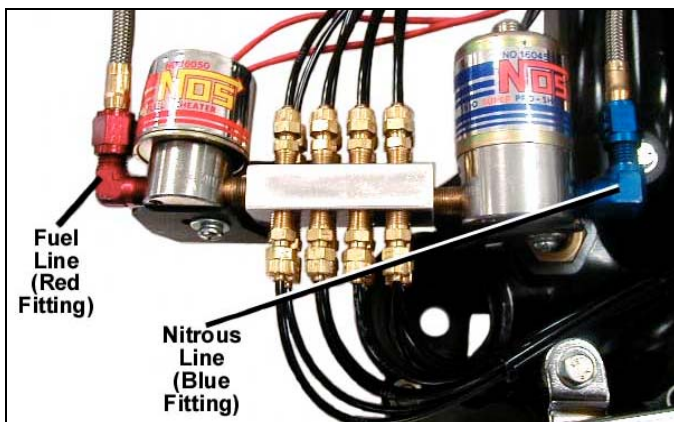


Figure 17

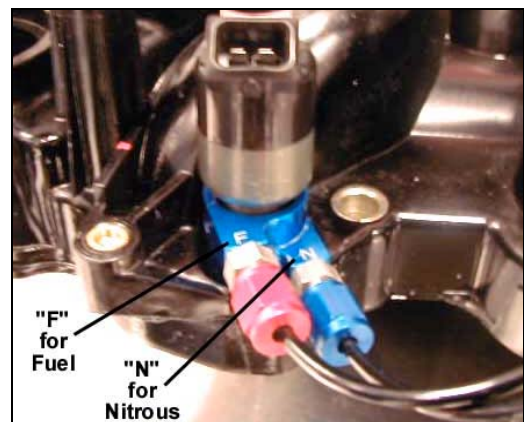


Figure 18

### 2.5.1 High-Pressure Line Installation

**NOTE:** When installing the high-pressure lines, tighten the fittings 1/16-1/8 of a turn after reaching a fingertight condition.

1. Route all 16 high-pressure supply lines from the distribution block to the NOSzles.
2. Install the selected jet size for your application and tighten the 3AN fittings to the NOSzles.

**WARNING! Failure to install the nitrous and/or fuel jet will result in catastrophic engine damage!**

3. Tie-wrap the high pressure hoses in bundles and arrange according to their end location avoiding tight turns or hose kinking, and contact with high temperature surfaces such as EGR supply tubes.

**WARNING! Kinked nitrous or fuel lines can result in inadequate mixture distribution resulting in catastrophic engine failure!**

### 2.6 Main Nitrous Feed Line Mounting

**CAUTION! Ensure that the nitrous supply line does not interfere with the exhaust system, suspension, steering, wheels and tires, electrical lines, and components.**

1. Examine the underbody of the vehicle to determine the nitrous supply line route.
2. Route the nitrous supply line along the proposed route. Keep the line away from the exhaust and moving components. Make sure the line is securely fastened. Rubber coated clamps are a good method for this.
3. Connect the main nitrous supply line to the solenoid inlet port. If required, drill a 5/8" hole for the N<sub>2</sub>O hose.

### 2.7 Main Fuel Pressure Safety Switch

1. The system comes with a fuel pressure safety switch. The purpose of this switch is to avoid nitrous activation if the fuel supply is not adequate to support the additional power generated during nitrous activation. The fuel pressure safety switch is preset to 35 psi.
2. Relieve fuel pressure via the Schrader valve. Collect fuel or clean any fuel spilled in the engine bay area.
3. Remove the Schrader valve.
4. Apply Teflon paste to all external pipe threads to ensure a leak-proof installation. Install the 1/16 NPT male to 1/8 NPT female adapter to the 1/8 NPT "T" fitting. Then install the T-pipe fitting assembly into the fuel rail. Orient the valve to locate the pressure safety switch outlet towards the back of the vehicle and the main fuel supply outlet towards the front of the vehicle.

**CAUTION! Do not over-tighten the fitting as damage of the fuel rail might occur.**

5. Install fuel pressure safety switch to the rear-facing outlet of the T fitting (Figure 19). Apply Teflon paste to the NPT threads of the fuel pressure safety switch.

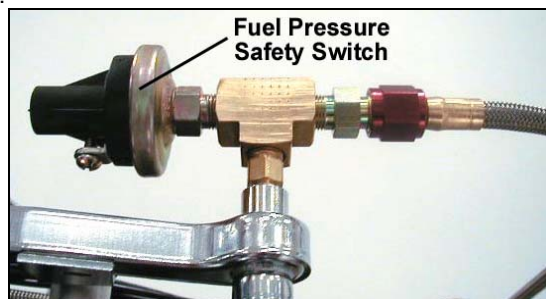


Figure 19

**CAUTION! When tightening the fuel pressure safety switch, support the T-fitting with a wrench to avoid fuel rail damage.**

### 2.8 Main Fuel Feed Line Installation

1. Install the main fuel supply line to the front outlet of the T fitting. Apply Teflon paste to the NPT threads of the main fuel supply hose.
2. Connect the other end of the main supply hose to the fuel solenoid inlet by generating a generous radius and avoiding any interference with rotating components and maintaining safe hood clearance.

## 2.9 Electrical System

Use the following procedures for the electrical system installation. See Figure 20 for the electrical wiring schematic.

**CAUTION!** Always disconnect your battery before completing any electrical wiring work.

**WARNING!** Death or injury may occur from working on a charged electrical system

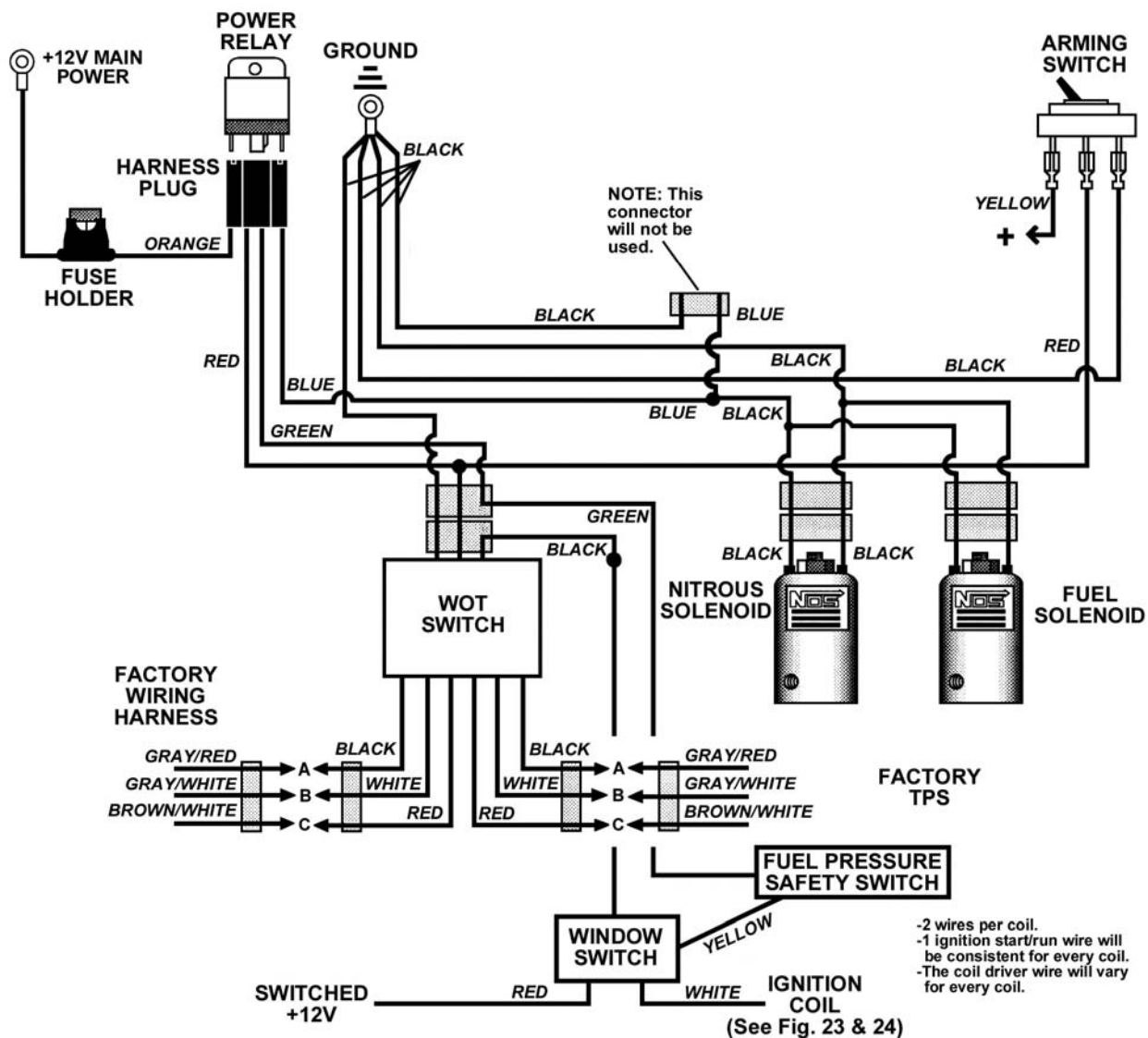


Figure 20

### 2.9.1 Wide-Open Throttle (WOT) Switch Installation

1. Mount the WOT Switch (30) in a convenient location. A good place to mount it is on the passenger side inner fenderwell. Use the supplied sheet metal screws to mount it, if desired.

**CAUTION!** When drilling or punching holes for these fasteners be aware what component, wires, or hoses are located or routed behind the general area to avoid vehicle or equipment malfunction.

2. Cut the three wires going to the TPS plug half way between the TPS and where the wires go into the harness. The factory insulation will have to be trimmed on both sides of the cut before new connectors can be terminated.
3. Install the 3-pin Female Connector (49) with the Female Packard Pins (46) and the Packard Seals (45) on the TPS lead from the factory wiring harness. See Figure 20 for wiring color codes and Figure 21 for Packard Connection Exploded View. It is recommended to use Packard Connector tool PN 12814254 to crimp the connectors. If this tool is not available, it is recommended to carefully crimp the connector pins on with pliers, and then solder the wire to the pin.

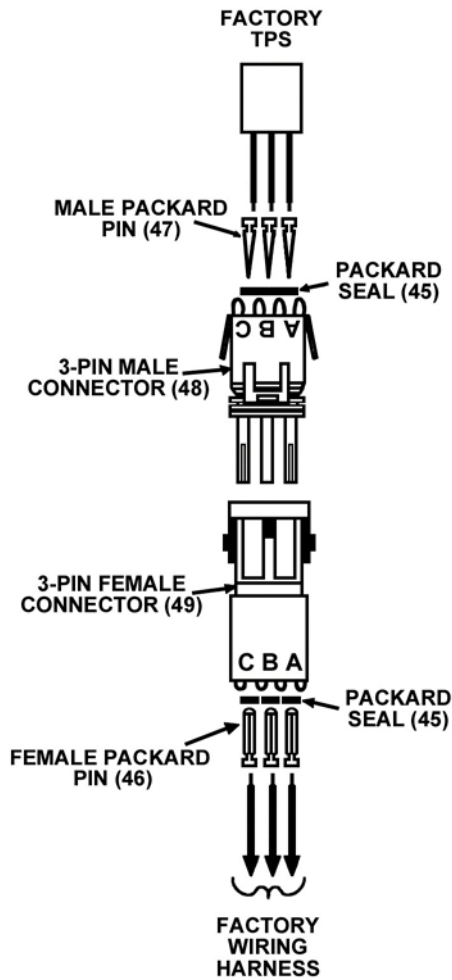


Figure 21 Packard Connection Exploded View

4. Install the 3-pin Male Connector (48), Male Packard Pins (47), and the Packard Seals (45) on the open end of the factory TPS plug lead. See Figure 20 for wiring codes and Figure 21 for Packard Connection Exploded View.
5. Connect the male plug from the WOT switch (30) to the female plug on the factory wiring harness.
6. Connect the female plug from the WOT switch (30) to the male plug on the factory TPS.

### 2.9.2 RPM Window Switch Installation (refer to Figure 20 for a complete electrical wiring diagram)

**CAUTION!** When drilling or punching holes for these fasteners be aware what component, wires or hoses are located or routed behind the general area to avoid vehicle or equipment malfunction.

1. An RPM window switch (32) is included with this NOSzle system. An RPM window switch allows for nitrous to only be activated in a selected RPM range. This provides two very important safety features: 1) It allows for the nitrous to only be activated at a safe RPM level, 2) It deactivates the nitrous before hitting the manufacturers set rev limiter in the engine control unit. If nitrous is activated at a very low rpm, possible engine damage can result. Hitting the engine control unit rev limiter with nitrous activated can cause severe engine damage.
2. The window switch needs to be wired properly. Please refer to Fig. 20, Fig. 22, and the directions given below.

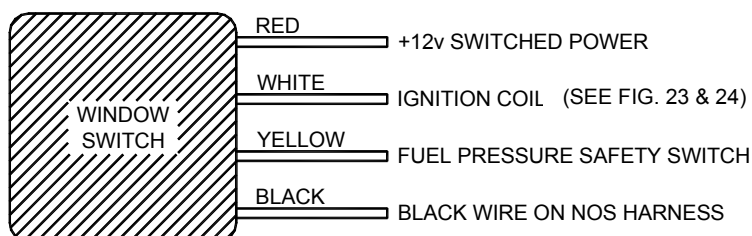


Figure 22



3. Connect the red wire to a switched +12 volt ignition power source. The same source use for the arming switch can be used.
4. **COIL ON PLUG**—The white wire of the RPM window switch needs to be connected to the negative side (coil driver) of one ignition coil. Choose the coil that best fits your wiring harness layout. Each ignition coil is supplied with a two-wire harness. Identify the color of the wires on at least 3 coils. One wire of the harness to each coil will have the same color from coil to coil. This is the ignition start/run wire. **Do not use this wire.** Use the other wire, which is the negative lead. The negative wire is the smaller gauge wire and color-coded differently for each coil to differentiate their cylinder location and the firing order of the engine. Any cylinder coil may be used, depending on the desired mounting location of the window switch. Use one of the T-tap terminals included and connect it to the negative coil wire. See Figure 23.
5. **COIL PACK**—The white wire of the RPM window switch needs to be connected to the negative side (coil driver) of one ignition coil. Choose the coil that best fits your wiring harness layout. Each ignition coil pack is supplied with a three-wire harness. Select one of the coil driver wires. This will be one of the outer wires of each harness. The positive ignition coil wire will be the middle wire on the coil pack. **Do not use this wire.** Use one of the T-tap terminals included and connect it to the negative coil wire. See Figure 24.

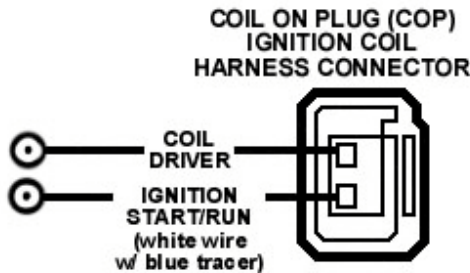


Figure 23—Coil On Plug—(1999 ½ & up)

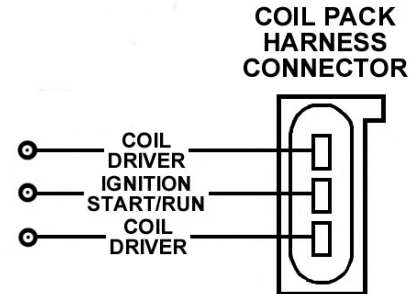


Figure 24—Coil Pack Harness—(1996-1999)

6. Connect the yellow wire of the RPM window switch to either side of the fuel pressure safety switch. Terminate the wire with one of the round ring terminals included.
7. Connect the black wire from the RPM window switch to the black wire on the main NOS harness. This black wire is loomed with a green wire on the NOS harness.
- 7A. For 1 coil per cylinder application (coil on plug): Use the 2600 RPM Module Chip (38) in the “ON” socket and the 6000 RPM Module Chip (39) in the “OFF” socket. This application is normally encountered in the Mustang (1999 ½ & up) models.
- 7B. For 2 coil packs (coil packs located on each bank of the engine): Use the 5200 RPM Module Chip (40) in the “ON” socket and the 12000 RPM Module Chip (41) in the “OFF” socket. This application is normally encountered in the Mustang (1996-1999) models.

**CAUTION!** This unit is supplied with the required ON and OFF RPM modules for a safe and reliable operation of the engine in your vehicle. Installation of RPM modules of different values may result in engine failure.

**NOTE:** To select different RPM ON & OFF values, use a module that is double the selected RPM. For example, 5200 module chip = 2600 RPM or 12,000 module chip = 6000 RPM, etc.

### 2.9.3 Arming Switch Installation

1. The arming switch needs to be mounted in the interior of your vehicle. Determine a position that is desirable. Drill a hole and mount the switch.

## 2.9.4 Harness Routing



Figure 25 –Main power connection

1. Uncoil the main wiring harness (18) and lay the unit out in the vehicle engine bay.
2. Mount the 30 amp relay socket securely to the vehicle. Figure 25 shows the place where it is designed to mount. Sheet metal screws are included to mount the relay.

**CAUTION!** When drilling or punching holes for these fasteners be aware what component, wires or hoses are located or routed behind the general area to avoid vehicle or equipment malfunction.

3. Attach the relay (20) to the socket.
  4. Install the 25 amp fuse (21) in the fuse holder.
  5. Terminate and connect the orange main power wire with a round ring terminal. The best place to do this is in the fuse box. See Figure 20 for this connection. Install the wire after the large fuse.
  6. Terminate and connect the black main ground wire with a round ring terminal. Use one of the existing vehicle grounds. Figure 20 shows a good ground to use.
  7. Route the nitrous and fuel solenoid connector to the passenger side of the engine compartment.
  8. Connect the TPS switch cable to the TPS module harness.
  9. Part of the harness has a red and a black wire that is for the arming switch. It needs to be routed inside the vehicle. Many times a grommet that is used for a factory harness is a good place to route the wires through. Be careful not to damage the stock harness.
- HINT:** A little extra time spent laying out the wiring loom at this stage will help ensure an attractive finished product. Carefully lay out the wiring harness in your car along the path you intend it to run. Ensure that all leads from the loom reach the components that they are intended to connect to. Ensure that the loom cannot contact engine exhaust, accessory drives, vehicle suspension, or braking components.
10. Secure the wiring harness to the factory harness, brackets, etc; using nylon tie wraps.

## 2.9.5 Solenoid Connection

1. Route the fuel and nitrous solenoid lead wires on the main wiring harness (2-pin female weather pack connector) to the nitrous (6) and fuel solenoids (7).
2. Connect the solenoid plug to the main wiring harness (18).

## 2.9.6 Arming Switch - Switched 12V Connection

1. Find the red and black wires that were routed into the interior. Cut them to the length they need to be to route neatly to the arming switch that was installed. Terminate them with female spade connectors. Connect the red wire to the pole marked “on accessory” on the switch. Connect the black wire to the pole marked “earth ground” on the switch.

**WARNING!** Check for any fuel leaks at this time!

2. A length of yellow wire (50) is included in the kit. This wire should be terminated with a female spade connector (43) and run to the arming switch. Connect it to the pole marked "supply volts". The other end runs to a 12 volt switched-ignition power source. Use a voltmeter to make sure the wire you use only has power when the ignition is on. Reconnect the battery to check this. Don't forget to disconnect the battery after you have checked the wire. Use the T-tap connector (included) to connect to the switched power wire. Terminate the other end of the yellow wire with a male spade connector (42) and connect this to the T-tap.

### 2.9.7 Fuel Pressure Safety Switch

1. The harness will contain green and black wire. The black wire was previously wired to the window switch. The green wire needs to be wired to the unused terminal on the fuel pressure safety switch. The other terminal was used to connect the yellow wire from the fuel pressure safety switch. Use a supplied round ring terminal for this.

### 2.10 Testing for Proper Operation without Nitrous Bottle Hooked Up

1. Connect battery.
2. Prime the fuel system by cycling the ignition switch from OFF to ON and back to OFF waiting 10 seconds for each interval.
3. Start the engine and check for leaks in the main fuel and secondary system: i.e. fuel injector, T-fitting on the fuel rail, fuel supply line to the fuel solenoid, fuel quick disconnect to the fuel rail, etc.
4. Check the TPS switch and window switch for proper operation. These are tested under WOT condition, monitoring the RPM and listening for the clicking sound when the solenoids are activated. WOT condition should be tested in a safe open road area and within legal driving limits. A small lamp can be used to indicate solenoid operation if the engine application does not allow listening for solenoid activation.
5. Make sure a filled nitrous bottle is **NOT open or connected** when performing all of these tests. If it is, engine damage might occur.
6. Start engine and run engine until reaching normal operating temperature.
7. Once in a safe open road area and with the arming switch turned "ON" (it should light up), move the gas pedal to the floor. When the engine reaches 2600 RPM you should hear the solenoids click on. At this time, additional fuel enrichment should be added. This will make the engine very rich. This verifies proper functioning of the system. Do not run the vehicle like this for an excessive period of time. When you let the pedal back up, the solenoids should click off. If proper functioning does not occur, call the NOS technical service department and troubleshoot the system.

### 2.11 Preparing for Operation

1. Install a fully charged nitrous bottle. The pressure gage should read 900-1000 psi.
2. Start the engine.
3. Open nitrous bottle valve.

**NOTE:** There should be no change in the engine idle speed or exhaust tone. If either changes, refer to Appendix A, Troubleshooting Guide.

4. Inspect the nitrous lines and fittings for leaks.
5. When you want to activate the nitrous, turn on the arming switch and it should light up. When the throttle is pressed wide open, the nitrous will automatically activate. The nitrous pressure should always be between 900 and 1000 PSI. If it is lower than this, lesser performance can result.

**WARNING! Never activate nitrous with the vehicle in "NEUTRAL" or "PARK"!**

**WARNING! The traction control must be turned OFF when using the nitrous, or engine damage may result!**

**NOTE: It is recommended to turn the traction control off when using the nitrous.**

6. ENJOY!

## Chapter 3 Tuning

Your NOS Kit Number 08100NOS is factory set to work with stock Ford 4.6L engine settings. For maximum performance, follow the settings listed in Table 2.

**Table 2 Tuning Suggestions for NOS Kit Number 08100NOS**

Configuration	N <sub>2</sub> O Jetting	Fuel Jetting	Fuel Quality	Ignition Timing	Plugs
100 HP	016	009	92+ Octane	Stock	1-2 steps colder than stock
125 HP	018	010	92+ Octane	Stock	2 steps colder than stock

Spark Plug Information:

Autolite PN	Steps Colder than Stock
103	1
AR94	2
AR93	3
AR92	4

## Appendix A Troubleshooting Guide

The troubleshooting chart on the following pages should help determine and rectify most problems with your installed NOS system. If you still need assistance determining or fixing problems, call NOS Technical Support at 1-714-546-0592.

PROBLEM	POSSIBLE CAUSES	DIAGNOSTIC PROCEDURE	CORRECTIVE ACTION
Engine runs rich when system is activated.	Bottle valve not fully opened.	Check bottle valve.	Open valve fully.
	Plugged nitrous filter.	Inspect filter.	Clean/replace filter.
	Low bottle pressure.	Check bottle temperature.	Set bottle temperature to 75° to 85°F.
	Inadequate nitrous supply.	Weigh bottle.	Fill bottle.
	Loose nitrous solenoid wiring.	Inspect the solenoid wiring.	Repair wiring.
No change in performance when system is activated.	Malfunctioning nitrous solenoid.	Disconnect solenoid / injector plug. Connect 12V test light to battery (-) terminal. Turn arming switch ON. Manually set microswitch ON. Use test light probe to check for continuity at blue wire on power relay.	Replace solenoid.  <i>* Below 70°F ambient, NOS Bottle Heater P/N 14164 is recommended to maximize performance.</i>
	System wired incorrectly.	Compare nitrous wiring to schematic (Figure 20).	Wire system per instructions.
	Loose ground wire(s).	Connect 12V test light to battery (+) terminal. Check for continuity at grounds noted in wiring schematic (Figure 20).	Tighten/repair loose ground(s).
	Malfunctioning arming switch.	With vehicle ignition ON, connect 12V test light to battery (-) terminal. Check for power at red wire on power relay switch.	Replace arming switch.
Malfunctioning fuel pressure safety switch.	Disconnect wires from fuel pressure safety switch. Connect a volt/ohm meter to each of the terminals. Resistance should be infinite or very large. <i>HINT: A volt/ohm meter with audible continuity signal would make the diagnostic process easier.</i> <b>Turn the key "ON", but DO NOT START THE ENGINE.</b> Read the resistance on the volt/ohm meter. It should be zero or very small. The audible continuity signal should be on. If resistance is still infinite or very high, or the audible continuity signal is not on, the fuel pressure safety switch is defective or the fuel pressure is too low.	Replace fuel pressure safety switch.	

	Malfunctioning WOT electronic switch	Disconnect 30 Amp power relay from wiring harness. Connect 12V test light to +12V source. With nitrous system armed and at WOT, probe the green wire connector in the 30 Amp power relay plug (wiring harness plug). Light should illuminate.	Replace WOT electronic switch.
	Malfunctioning power relay.	Temporarily disconnect solenoid / injector plug. Connect 12V test light to battery (-) terminal. Turn arming switch ON. Manually set microswitch ON. Use test light probe to check for continuity at blue wire on power relay.	Replace power relay.
	In-line fuse blown.	Check fuse.	Replace fuse.
Engine detonates mildly when system is activated.	Excessive ignition timing.	Check ignition timing.	Set timing to factory settings.
	Inadequate octane fuel.		Use higher octane fuel.
	Spark plug heat range too high.		Reduce spark plug heat range (maximum two steps).
	Too much nitrous flow.		Reduce nitrous jetting.
Engine detonates heavily when system is activated.	Inadequate fuel delivery due to: Plugged fuel filter	Inspect fuel filter.	Clean or replace filter.
	Crimped fuel line.	Inspect fuel line.	Replace crimped line.
	Weak fuel pump.	Install fuel pressure gauge, such as NOS P/N 15931. Compare fuel pressure with factory-specified values.	Repair/replace fuel pump.
High RPM misfire when system is activated.	Excessive spark plug gap.	Inspect spark plugs.	Set spark plug gap at 0.030 to 0.035 inches.
	Weak ignition/ignition component failure.	Inspect components (plug wires, distributor cap, etc.)	Replace worn components.
Surges under acceleration when system is activated.	Inadequate supply of nitrous.	Check bottle weight.	Replace with full bottle.
	Bottle mounted incorrectly.	Compare bottle position and orientation to instructions.	Mount or orient bottle correctly.

**Nitrous Oxide Systems, Inc.**  
**1357 E. Grand Ave.**  
**Pomona, CA 91766**  
**Tech Service: 1-714-546-0592**  
**Fax: 1-714-545-8319**  
**Email: nos@support.holley.com**

**199R-10272**  
**Date: 3-18-02**